

**Acuity AR100
Triangulation Sensor Manual
Revision 1.1 on 2.6.2018**



**© 2018 Schmitt Industries
2765 NW Nicolai St.
Portland, OR 97210 USA**

**sales@acuitylaser.com
Tel: +1 503.227.7908
Fax: +1 503.223.1258
Acuitylaser.com**

Acuity is a product line of



schmittindustries.com

Table of Contents

Safety Precautions	4
CE compliance	4
Laser safety	4
General information	4
Basic technical data	5
Options to designate when ordering the AR100	6
Structure and operational principle	6
Dimensions and mounting	7
Overall and mounting dimensions	7
Overall demands for mounting.....	7
Connection	8
Configuration parameters	8
Time limit for integration	8
Sampling mode.....	9
Sampling period	9
Zero point.....	10
Line AL operation mode	10
Time lock of the result	12
Method of results averaging.....	12
Number of averaged values/time of averaging.....	12
Factory parameters table	12
Description of RS232 and RS485 interfaces	13
RS232 port	13
RS485 port	13
Serial data transmission format	13
Modes of data transfer	13
Communication sessions types	13
Configuration parameters	14
Rate of data transfer through serial port	14
Net address	14
Factory parameters table.....	14
Acuity protocol (binary format)	14
Request.....	14
Answer	15
Data stream.....	16
Output rate	16
Request code table.....	16
Notes.....	18
Modbus RTU protocol (binary format)	22
Input Registers (Read only)	22
Holding Registers (Read / Write)	22
ASCII format	23

Analog outputs	25
Current output 4...20 mA	25
Voltage output 0...10 V	26
Configuration parameters	26
Range of the analog output	26
Analog output operation mode.....	27
Factory parameters table	27
Parameterization program	27
Function	27
Program setup	27
Obtaining connection to sensor (RS232/RS485)	28
Checking of the sensor operability	29
Connection via the ASCII interface	30
Connection via the Modbus RTU protocol	31
Display, gathering and scanning of data	32
Setting and saving parameters of the sensor	33
Setting parameters	33
Automatic data stream mode after power switch on.....	34
Saving parameters	34
Saving and writing a set of parameters.....	34
Recovery of default parameters.....	35

Safety Precautions

- Use supply voltage and interfaces indicated in the sensor specifications
- In connection/disconnection of cables, the sensor power must be switched off
- Do not use sensors in locations close to powerful light sources
- To obtain stable results, wait about 20 minutes after sensor activation to achieve uniform sensor warm-up

CE compliance

The sensors have been developed for use in industry and meet the requirements of the following Directives:

- EU directive 2014/30/EU. Electromagnetic compatibility (EMC).
- EU directive 2011/65/EU, “RoHS“category 9.

Laser safety

The sensors make use of a c.w. 660 nm (or 405 nm, 450 nm) wavelength semiconductor laser. The maximum output power is 0.95 mW. The sensors belong to the 2 laser safety class. The following warning label is placed on the sensor body:

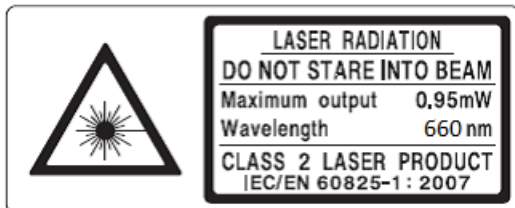

The following safety measures should be taken while operating the sensor:

- Do not target the laser beam to humans;
- Do not disassemble the sensor;
- Avoid staring into the laser beam.

General information

The sensors are intended for non-contact measuring and checking of position, displacement, dimensions, surface profile, deformation, vibrations, sorting and sensing of technological objects as well as for measuring levels of liquid and bulk materials.

The series includes 6 models of sensors with the measurement range from 10 to 500 mm and the offset distance from 20 to 105 mm.

There are two options of laser sensors: RED laser (660 nm) or BLUE laser (405 or 450 nm). The use of blue lasers instead of conventional red lasers greatly enhances capabilities of the sensors, in particular, for such uses as control of high-temperature objects and organic materials.

Basic technical data

AR100	-10	-25	-50	-100	-250	-500
Base distance, mm	20	20	30	50	65	105
Range, mm	10	25	50	100	250	500
Linearity, %	±0.05% of the range					±0.1%
Resolution, %	0.01% of the range (for the digital output only)					0.02%
Temperature drift	0.02% of the range per /°C					
Max. measurement frequency, Hz	9,400 Hz					
Light source	red semiconductor laser, 660 nm wavelength; blue or UV semiconductor laser, 405 nm or 450 nm wavelength (BLUE version)					
Output power	≤0.95 mW					
Laser safety class	2 (IEC60825-1)					
Output interface:						
	<i>digital</i>	RS232 or RS485 (max. 921.6 Kbit/s)				
	<i>analog</i>	4...20 mA (load <input type="checkbox"/> 500 Ohm) or 0...10				
Synchronization input	2.4 – 24 Volts					
Logic output	programmed functions, NPN: 100 mA max; 40 V max					
Power supply	9 ...36 Volts					
Power consumption	1.5..2 Watts					
Environmental resistance:						
	<i>Enclosure rating</i>	IP67				
	<i>Vibration</i>	20 g /10...1000 Hz, 6 hours for each of XYZ axes				
	<i>Shock</i>	30 g / 6 ms				
	<i>Operating ambient temperature</i>	-10...+60 °C				
	<i>Permissible</i>	10,000				

<i>ambient light, lux</i>	
<i>Relative humidity</i>	5-95% (no condensation)
<i>Storage temperature</i>	-20...+70 °C
Housing material	aluminum
Weight (without cable)	40 gram

Options to designate when ordering the AR100

	Description
1	Red or Blue laser option (450 nm)
2	Measurement range, mm
3	The type of serial interface: 232 (RS232) or 485 (RS485)
4	Analog output of either: 4...20 mA (I) or 0...10 Volts (U)
5	Synchronization input
6	User programmable input/output signal
7	Standard cable length is 2 meter with options for longer cable lengths

Structure and operational principle

Operation of the sensors is based on the principle of optical triangulation (Figure 1). Radiation of a semiconductor laser (1) is focused by a lens (2) onto an object (6). Radiation reflected by the object is collected by a lens (3) onto a linear CMOS array (4). Moving the object (6 - 6') causes the corresponding shift of the image. A signal processor (5) calculates the distance to the object from the position of the light spot on the array (4).

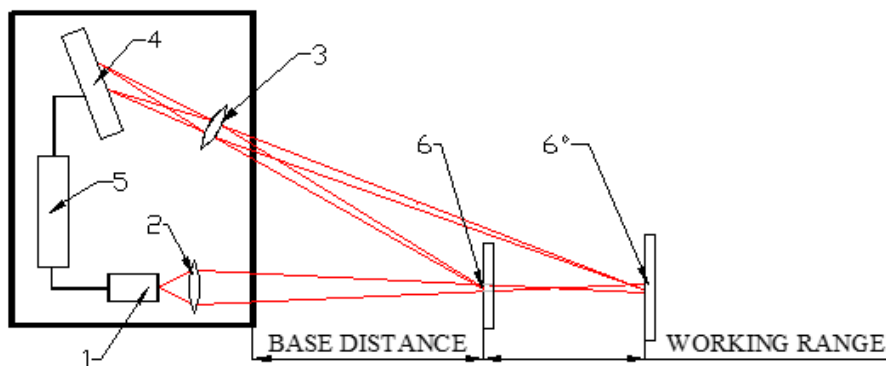
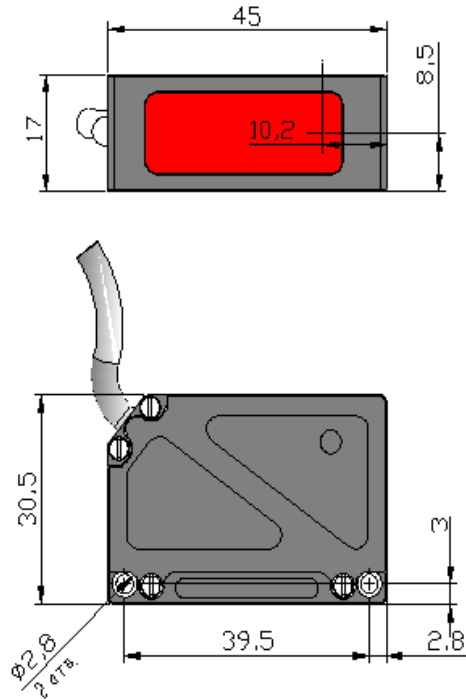

Figure 1

Dimensions and mounting

Overall and mounting dimensions

Overall and mounting dimensions of the sensors are shown in Figure 2. The sensor housing is made of anodized aluminum. The front panel of the housing has a glass window. The housing also contains mounting holes. The cable is mounted on the sensor without connector.



Overall demands for mounting

The sensor is positioned so that the object under control has to be placed in the working range of the sensor. In addition, no foreign objects should be allowed to stay on the path of the incident and reflected laser radiation.

Where the objects to be controlled have intricate shapes and textures, the incidence of mirror component of the reflected radiation to the receiving window should be minimized.

Connection

Assignment of the cable wires is shown in the table below:

Model of the sensor	Pin number	Assignment	Wire color	
232-U/I-IN-AL	free lead	-	Power 9 to 36 Volts+	Red
	free lead	-	Ground (power)	Brown
	DB9	2	TXD	Green
	DB9	3	RXD	Yellow
	free lead	-	Voltage / Current	Blue
	free lead	-	IN	Violet
	free lead	-	AL	Orange
	DB9	5	Ground (common for signals)	Black
485-U/I-IN-AL	free leads	-	Power 9 to 36 Volts+	Red
		-	Ground (power)	Brown
		-	DATA+	Green
		-	DATA-	Yellow
		-	Voltage / Current	Blue
		-	IN	Violet
		-	AL	Orange
-	Ground (common for signals)	Black		

Configuration parameters

The nature of operation of the sensor depends on its configuration parameters, which can be changed only by transmission of commands through serial port RS232 or RS485. The basic parameters are as follows:

Time limit for integration

Intensity of the reflected radiation depends on the surface characteristics of the object under control. Therefore, the output power of the laser and the time of integration of radiation incident onto the CMOS-array are automatically adjusted to achieve the maximum measurement accuracy.

Parameter "time limit for integration" specifies the maximum allowable time of integration. If the radiation intensity received by the sensor is so small that no reasonable result is obtained within the time of integration equal to the limiting value, the sensor transmits a zero value.

Note 1. The measurement frequency depends on the integration time of the receiving array. The maximum frequency (9.4 kHz) is achieved for the integration time $\leq 106 \mu\text{s}$ (minimum possible integration time is $3 \mu\text{s}$). As the integration time increases above $106 \mu\text{s}$, the result updating time reduces proportionally.

Note 2. Increasing of this parameter expands the possibility of control of low-reflecting (diffuse component) surfaces; at the same time this leads to reduction of measurement frequency and increases the effects of exterior light (background) on the measurement accuracy. Factory setting of the limiting time of integration is $3200 \mu\text{s}$.

Note 3. Decreasing of this parameter lets to increase the measurement frequency, but can decrease the measurement accuracy.

Sampling mode

This parameter specifies one of the two result sampling options in the case where the sensor works in the data stream mode:

- Time Sampling;
- Trigger Sampling.

When *Time Sampling* is selected, the sensor automatically transmits the measurement result via serial interface in accordance with the selected time interval (sampling period).

When *Trigger Sampling* is selected, the sensor transmits the measurement result when the external synchronization input (IN input of the sensor) is switched and taking *the division factor* set into account.

Sampling period

If the Time Sampling mode is selected, the 'sampling period' parameter determines the time interval in which the sensor will automatically transmit the measurement result. The time interval value is set in increments of $1 \mu\text{s}$.

If the Trigger Sampling mode is selected, the 'sampling period' parameter determines the division factor for the external synchronization input. **For example**, for the parameter value equal to 100, data are transmitted through bit-serial interface when each 100th synchronizing pulse arrives at IN input of the sensor.

Note 1. It should be noted that the 'sampling mode' and 'sampling period' parameters control only the transmission of data. The sensor operation algorithm

is built so that measurements are taken at a maximum possible rate determined by the integration time period, the measurement results are sent to buffer and stored therein until a new result arrives. The above-mentioned parameters determine the method of the readout of the result from the buffer.

Note 2. If the bit-serial interface is used to receive the result, the time required for data transmission at selected data transmission rate should be taken into account in the case where small sampling period intervals are used. If the transmission time exceeds the sampling period, it is this time that will determine the data transmission rate. The calculation of time required to transmit the result is given on p.16.

Note 3. It should be taken into account that the sensors differ in some variation in the parameters of the internal generator, which affects the accuracy of the Time Sampling period.

Zero point

This parameter sets a zero point of absolute system of coordinates in any point within the limits of a working range. You can set this point by corresponding command or by connecting AL input to the ground line (this input must beforehand be set to mode 4). When the sensor is fabricated, the base distance is set with a certain uncertainty, and, if necessary, it is possible to define the point zero more accurately.

Line AL operation mode

This line can work in one of the eight modes defined by the configuration parameter value:

- mode 1: indication of run-out beyond the range;
- mode 2: mutual synchronization of two or more sensors (slave);
- mode 3: mutual synchronization of two or more sensors (master);
- mode 4: hardware zero-set line;
- mode 5: hardware laser switch OFF/ONN;
- mode 6: encoder;
- mode 7: input;
- mode 8: reset of the Ethernet packets counter.

In the *"Indication of run-out beyond the range"* mode, logical "1" occurs on the AL line if an object under control is located within the working range of the sensor (within the selected window in the range), and logical "0" occurs if the object is absent in the working range (within the selected window). For example, in such mode this line can be used for controlling an actuator (a relay), which is activated when the object is present (absent) within the selected range (Fig. 6.1).

The "Mutual synchronization" mode makes it possible to synchronize measurement times of two and more sensors. It is convenient to use this mode to control one object with several sensors, e.g., in the measurement of thickness.

On the hardware level, synchronization of the sensor is effected by combining AL lines (Fig. 6.2.). Using the parameterization program, one of the sensors should be set to the "Master" mode, and the rest - to the "Slave" mode.

In the "Hardware zero-set" mode, connection AL input to the ground potential sets the beginning of coordinates into the current point (Fig. 6.3.)*.

In the "Hardware laser switch OFF/ON" mode, connection AL input to the ground potential switches the laser ON/OFF (Fig. 6.3.)*.

In the "Encoder" mode, the AL and IN lines work as inputs of quadrature signals. In this mode, the encoder can be connected to these lines, and the measurements will be synchronized with the encoder.

In the "Input" mode, the AL line state is transmitted in the status word in the Ethernet packet.

In the "Reset of the Ethernet packets counter" mode, connection AL input to the ground potential resets the counter (Fig. 6.3.)*.

***Note.** A low level of the AL line is holding for 100 μ s or more, and a high level of the AL line is holding for 100 μ s.

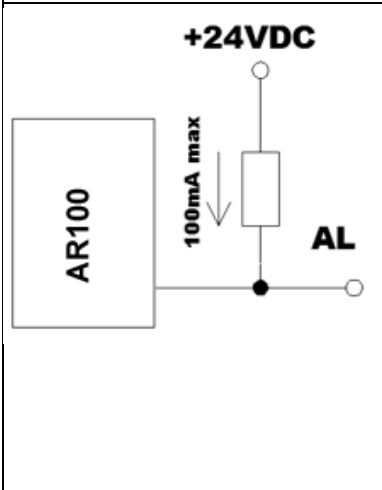
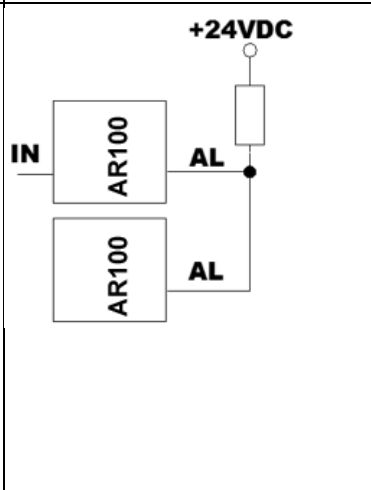
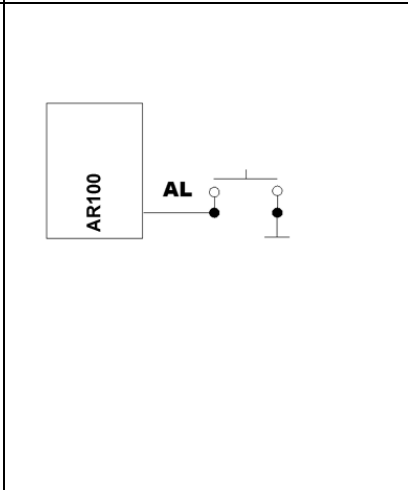
Out of the range indication	Mutual synchronization	Hardware zero-set/ Hardware laser ON/OFF
		
<p>Figure 6.1.</p>	<p>Figure 6.2.</p>	<p>Figure 6.3.</p>

Time lock of the result

If the sensor does not find the object or if the authentic result cannot be received, a zero value is transferred. The given parameter sets time during which the last authentic result is transferred.

Method of results averaging

This parameter defines one of the two methods of averaging of measurement results implemented directly in the sensor:

- Averaging over a number of results
- Time averaging

When averaging over a number of results is selected, sliding average is calculated.

When time averaging is selected, the results obtained are averaged over the time interval chosen.

Number of averaged values/time of averaging

This parameter specifies the number of source results to be averaged for deriving the output value or time of the averaging.

The use of averaging makes it possible to reduce the output noise and increase the sensor resolution.

Averaging over a number of results does not affect the data update in the sensor output buffer.

In case of time averaging, data in the output buffer are updated at a rate equal to the averaging period.

Note. The maximum value is 127.

Factory parameters table

The sensors are supplied with the parameters shown in the table below:

Parameter	Value
Time limit for integration	3200 (3.2 milliseconds)
Sampling mode	time
Sampling period - microseconds	5000 (5 milliseconds)
Point of zero	Beginning of the range
Line AL operation mode	1
Time lock of the result	2 (10 milliseconds)
Method of results averaging	Over a number of results
Number of averaged values	1

The parameters are stored in nonvolatile memory of the sensor. Correct changing of the parameters is carried out by using the parameterization program supplied with the sensor or a user program.

Description of RS232 and RS485 interfaces

Data exchange with the sensor is carried out over the Acuity or Modbus RTU protocols in binary format or in the ASCII format. The protocol and the data format are selected using the parameterization program.

RS232 port

The RS232 port ensures a “point-to-point” connection and allows the sensor to be connected directly to RS232 port of a computer or controller.

RS485 port

In accordance with the protocol accepted and hardware capability, the RS485 port makes it possible to connect up to 127 sensors to one data collection unit by a common bus circuit.

Serial data transmission format

Data message has the following format:

1 start-bit	8 data bits	1 even bit	1 stop-bit
-------------	-------------	------------	------------

Modes of data transfer

Through these serial interfaces the measurement data can be obtained by two methods:

- by single requests (inquiries);
- by automatic data streaming (stream).

Communication sessions types

The communications protocol is formed by communication sessions, which are only initiated by the ‘master’ (PC, controller). There are two kinds of sessions with such structures:

- 1) “request”, [“message”] — [“answer”], square brackets include optional elements.
- 2) “request” — “data stream” — [“request”].

Configuration parameters

Rate of data transfer through serial port

This parameter defines the rate of data transmission via the bit-serial interface in increments of 2,400 bit/s. **For example**, the parameter value equal to 4 gives the transmission rate of $2400 \times 4 = 9600$ bit/s.

Note. The maximum transmission rate for RS232 and RS485 interfaces is 921.6 Kbit/s.

Net address

This parameter defines the network address of the sensor equipped with RS485 interface.

Note. The network data communication protocol assumes the presence of a 'master' in the net, which can be a computer or other information-gathering device, and from 1 to 127 'slaves' (AR100 Series sensors) which support the protocol.

Each 'slave' is assigned a unique network identification code – a device address. The address is used to form requests or inquiries all over the net. Each slave receives inquiries containing its unique address as well as '0' address which is broadcast-oriented and can be used for formation of generic commands, for example, for simultaneous latching of values of all sensors and for working with only one sensor (with both RS232 port and RS485 port).

Factory parameters table

Parameter	Value
Baud rate (RS232 or RS485)	9600 bit/s
Net address	1
Mode of data transfer	request

Acuity protocol (binary format)

Request

'Request' is *a two-byte* message, which fully controls a communication session and can be transmitted by the 'master'. The 'request' message is the only one of all messages in a session where *the most significant bit is set at 0*, therefore, it serves to synchronize the beginning of the session. In addition, it contains the device address (ADR), code of request (COD) and, optionally, the message [MSG].

Request format ('master'):

Byte	Bits								Description
	7	6	5	4	3	2	1	0	
0	0	ADR							network address
1	1	0	0	0	COD			code of request	
2	1	0	0	0	MSG[0] lo			lower tetrad of the 0th byte	
3	1	0	0	0	MSG[0] hi			higher tetrad of the 0th byte	
4	1	0	0	0	MSG[1] lo			lower tetrad of the 1st byte	
5	1	0	0	0	MSG[1] hi			higher tetrad of the 1st byte	
...	

Answer

'Answer' is the data burst that can be transmitted by 'slave' in the course of the session.

All messages with a message burst contain 1 in the most significant digit. *Data in a message are transferred in tetrads.* When byte is transmitted, lower tetrad goes first, and then follows higher tetrad. When multi-byte values are transferred, the transmission begins with lower byte.

When 'answer' is transmitted, the message contains:

- SB-bit, characterizes the updating of the result. If SB is equal to "1", this means that the sensor has updated the measurement result in the buffer, if SB is equal to "0" - then non-updated result has been transmitted. SB=0 when parameters transmit;
- two additional bits of cyclic binary batch counter (CNT). Bit values in the batch counter are identical for all sending's of one batch. The value of batch counter is incremented by the sending of each burst and is used for formation (assembly) of batches or bursts as well as for control of batch losses in receiving data streams.

The following is the format of the 'answer' data burst for the message transmission (MSG):

Byte	Bits								Description
	7	6	5	4	3	2	1	0	
0	1	SB	CNT		MSG[0] lo			lower tetrad of the 0th byte	
1	1		CNT		MSG[0] hi			higher tetrad of the 0th byte	
2	1	SB	CNT		MSG[1] lo			lower tetrad of the 1st byte	
3	1		CNT		MSG[1] hi			higher tetrad of the 1st byte	
...	

Data stream

'Data stream' is an infinite sequence of data bursts or batches transmitted from 'slave' to 'master', which can be interrupted by a new request. In transmission of 'data stream' one of the 'slaves' fully holds a data transfer channel, therefore, when 'master' produces any new request sent to any address, data streaming process is stopped. Also, there is a special request to stop data streaming.

Output rate

Output rate ("OR") depends on Baud rate of serial interface ("BR"), and is calculated by such a manner:

$$OR = 1 / (44/BR + 1 * 10^{-5}) \text{ Hz}$$

For example, for BR=460800 b/s, Output rate = 9.4 kHz.

Request code table

Reque st code	Description	Message (size in bytes)	Answer (size in bytes)
01h	Device identification	—	- device type (1) - firmware version (1) - serial number (2) - base distance (2) - range (2)
02h	Read a parameter	- code of parameter (1)	- value of parameter (1)
03h	Write a parameter	- code of parameter (1) - value of parameter (1)	—
04h	Store current parameters to FLASH-memory	- constant AAh (1)	- constant AAh (1)
04h	Recover default values of parameters in FLASH-memory	- constant 69h (1)	- constant 69h (1)
05h	Latch a current result	—	—
06h	Request a result	—	- result (2)
07h	Request a stream of results	—	- stream of result (2)
08h	Stop data streaming	—	—

1.1.1. List of parameters

Code of parameter	Description	Values
00h	Sensor ON	1 — laser is ON, measurements are taken (default); 0 — laser is OFF, sensor in power save mode.
01h	Analog output ON	1 — analog output is ON; 0 — analog output is OFF.
02h	Control of averaging, sampling, AL and analog output	x,M2,A,C,M1,M0,R,S – control byte which determines the operation mode. M2:M1:M0 bits (AL mode): 000 - out of the range indication (by default); 001 - 'slave' mode (mutual synchronization); 010 - hardware zero set mode; 011 - laser switch OFF/ON; 100 - encoder mode; 101 - input mode; 110 - reset of the Ethernet packets counter; 111 - 'master' mode (mutual synchronization). A bit (averaging mode): 0 - averaging over a number of results (by default); 1 - time averaging (5 ms). C bit is not used R bit (analog output mode): 0 - window mode (by default); 1 - full range. S bit (sampling mode): 0 - time sampling (by default); 1 - trigger sampling. x bit is not used
03h	Network address	1...127 (default — 1)
04h	Rate of data transfer through a serial port	1...192 (default — 4), specifies data transfer rate in increments of 2400 baud; e.g., 4 means the rate of 4*2400=9600 baud.
05h	Reserved	
06h	Number of averaged values	1...128 (default — 1)

07h	Reserved	
08h	Lower byte of the sampling period	1) 10...65535 (default — 5000) The time interval in increments of 1 μ s with which sensor automatically communicates the results on streaming request (priority of sampling = 0). 2) 1...65535 (default — 5000) Divider ratio of trigger input (priority of sampling = 1).
09h	Higher byte of the sampling period	
0Ah	Lower byte of maximum integration time	2...3200 (default – 3200) The limiting time of integration by CMOS-array in increments of 1 μ s.
0Bh	Higher byte of maximum integration time	
0Ch	Lower byte for the beginning of analog output range	0...16383 (default – 0)
0Dh	Higher byte for the beginning of analog output range	
0Eh	Lower byte for the end of analog output range	0...16383 (default – 16383)
0Fh	Higher byte for the end of analog output range	
10h	Time lock of result	0...255, specifies the time interval in increments of 5 milliseconds.
11...16h	Reserved	
17h	Lower byte of a zero point	0...16383 (default — 0), specifies the beginning of absolute coordinate system.
18h	Higher byte of a zero point	
19...88h	Reserved	
89h	Autostart of the stream when the sensor is turned on (after 20 seconds)	1 — Autostart is ON; 0 — Autostart is OFF (default).
8Ah	Protocols for RS232/RS485 interfaces	0 — ACUITY protocol (default); 1 — ASCII protocol; 2 — MODBUS RTU protocol.

Notes

- All values are given in binary form.
- Base distance and range are given in millimeters.
- The value of the result transmitted by a sensor (D) is so normalized that 4000h (16384) corresponds to a full range of the sensor (S in mm), therefore, the result in millimeters is obtained by the following formula:

$X=D*S/4000h$ (mm) (1)

- On special request (05h), the current result can be latched in the output buffer where it will be stored unchanged up to the moment of arrival of request for data transfer. This request can be sent simultaneously to all sensors in the net in the broadcast mode in order to synchronize data pickup from all sensors.
- When working with the parameters, it should be borne in mind that when power is OFF the parameter values are stored in nonvolatile FLASH-memory of the sensor. When power is ON, the parameter values are read out to RAM of the sensor. In order to retain these changes for the next power-up state, a special command for saving current parameter values in the FLASH-memory (04h) must be run.
- Parameters with the size of more than one byte should be saved starting from the high-order byte and finishing with the low-order byte.
- **ATTENTION!** It is not recommended to configure the network addresses of the sensors connected to the network using the "common bus" scheme (RS485).

1.1.2. Examples of communication sessions

1) Request: "Device identification".

Conditions: device address - 1, request code - 01h, device type - 63 (3Fh), firmware version - 144 (90h), serial number - 17185 (4321h), base distance - 80 mm (0050h), measurement range - 50 mm (0032h), packet number (CNT) - 1, result update flag (SB) - 0.

Request ('master'):

Byte	Bits								Value	Description
	7	6	5	4	3	2	1	0		
0	0	0	0	0	0	0	0	1	01h	Network address
1	1	0	0	0	0	0	0	1	81h	Request code

Answer ('slave'):

Byte	Bits								Value	Description
	7	6	5	4	3	2	1	0		
0	1	0	0	1	1	1	1	1	9Fh	Lower tetrad of the device type
1	1	0	0	1	0	0	1	1	93h	Higher tetrad of the device type
2	1	0	0	1	0	0	0	0	90h	Lower tetrad of the firmware version
3	1	0	0	1	1	0	0	1	99h	Higher tetrad of the firmware version
4	1	0	0	1	0	0	0	1	91h	Lower tetrad of the 0th byte of a serial number
5	1	0	0	1	0	0	1	0	92h	Higher tetrad of the 0th byte of a serial number
6	1	0	0	1	0	0	1	1	93h	Lower tetrad of the 1st byte of a serial

										number
7	1	0	0	1	0	1	0	0	94h	Higher tetrad of the 1st byte of a serial number
8	1	0	0	1	0	0	0	0	90h	Lower tetrad of the 0th byte of a base distance
9	1	0	0	1	0	1	0	1	95h	Higher tetrad of the 0th byte of a base distance
10	1	0	0	1	0	0	0	0	90h	Lower tetrad of the 1st byte of a base distance
11	1	0	0	1	0	0	0	0	90h	Higher tetrad of the 1st byte of a base distance
12	1	0	0	1	0	0	1	0	92h	Lower tetrad of the 0th byte of the range
13	1	0	0	1	0	0	1	1	93h	Higher tetrad of the 0th byte of the range
14	1	0	0	1	0	0	0	0	90h	Lower tetrad of the 1st byte of the range
15	1	0	0	1	0	0	0	0	90h	Higher tetrad of the 1st byte of the range

2) Request: "Reading of parameter".

Conditions: device address - 1, request code - 02h, parameter code - 05h, parameter value - 04h, packet number (CNT) - 2, result update flag (SB) - 0.
Request ('master'):

Byte	Value	Description
0	01h	Network address
1	82h	Request code
2	82h	Lower tetrad of the parameter code
3	80h	Higher tetrad of the parameter code

Answer ('slave'):

Byte	Value	Description
0	A4h	Lower tetrad of the parameter value
1	A0h	Higher tetrad of the parameter value

3) Request: "Inquiring of result".

Conditions: device address - 1, result value - 677 (02A5h), packet number (CNT) - 3, result update flag (SB) - 1.

Request ('master'):

Byte	Value	Description
0	01h	Network address
1	86h	Request code

Answer ('slave'):

Byte	Value	Description
0	F5h	Lower tetrad of the 0th byte of the result value
1	FAh	Higher tetrad of the 0th byte of the result value
2	F2h	Lower tetrad of the 1st byte of the result value
3	F0h	Higher tetrad of the 1st byte of the result value

Measured distance (mm) (for example, range of the sensor = 50 mm):

$$X=677(02A5h)*50/16384 = 2.066 \text{ mm}$$

4) Request: "Writing sampling regime (trigger sampling)".

Conditions: device address - 1, request code - 03h, parameter code - 02h, parameter value - 01h.

Request ('master'):

Byte	Value	Description
0	01h	Network address
1	83h	Request code
0	82h	Lower tetrad of the parameter code
1	80h	Higher tetrad of the parameter code
2	81h	Lower tetrad of the parameter value
3	80h	Higher tetrad of the parameter value

5) Request: "Writing the divider ration".

Condition: divider ration - 1234 (3039h), device address - 1, request code - 03h, parameter code - 09h (first or higher byte), parameter value - 30h.

Request ('master'):

Byte	Value	Description
0	01h	Network address
1	83h	Request code
0	89h	Lower tetrad of the parameter code
1	80h	Higher tetrad of the parameter code
2	80h	Lower tetrad of the parameter value
3	83h	Higher tetrad of the parameter value

and for lower byte, parameter code - 08h, parameter value - 39h.

Request ('master'):

Byte	Value	Description
0	01h	Network address
1	83h	Request code
0	88h	Lower tetrad of the parameter code
1	80h	Higher tetrad of the parameter code
2	89h	Lower tetrad of the parameter value
3	83h	Higher tetrad of the parameter value

Modbus RTU protocol (binary format)

Input Registers (Read only)

Register / Address	Description	Example
1	Device type	63
2	Firmware version	40
3	Serial number	19999
4	Base distance	125
5	Measurement range	500
6	Measured value	15894

Holding Registers (Read / Write)

Register / Address	Description	Value
10	Sensor ON	1 — laser is ON, measurements are taken (default state); 0 — laser is OFF, sensor in power save mode.
11	Analog output ON	1 — analog output is ON; 0 — analog output is OFF.
12	Control of averaging, sampling, AL-output modes	<p>x,x,x,x,x,x,x,x,M2,A,C,M1,M0,R,S - control register, which determines the operation mode: averaging - M bit, CAN interface - C bit, logic output - M0:M2 bits, analog output - R bit, sampling mode - S bit; x bits are not used.</p> <p>M2:M0 bits:</p> <ul style="list-style-type: none"> 000 - out of the range indication (default); 001 - 'slave' mode (mutual synchronization); 010 - hardware zero set mode; 011 - laser switch OFF/ON; 100 - encoder mode; 101 - input mode; 110 - reset of the Ethernet packets counter; 111 - 'master' mode (mutual synchronization). <p>A bit:</p> <ul style="list-style-type: none"> 0 - averaging over a number of results (default); 1 - time averaging (5 ms). <p>C bit:</p> <ul style="list-style-type: none"> 0 - CAN interface mode by request (default); 1 - CAN interface mode with synchronization by

		time or trigger. R bit: 0 - window mode (default); 1 - full range. S bit: 0 - time sampling (default); 1 - trigger sampling.
13	Network address	1...128 (default — 1)
14	Rate of data transfer through a serial port	1...192 (default — 4) Specifies data transfer rate in increments of 2400 baud; e.g., 4 means the rate of 4*2400=9600 baud.
15	Number of averaged values	1...128 (default — 1)
16	Sampling period	1) 100...65535 (default — 5000) The time interval in increments of 1 μ s with which sensor automatically communicates the results on streaming request (sampling mode = 0). 2) 1...65535 (default — 5000) Divider ratio of trigger input (sampling mode = 1).
17	Maximum integration time	3...3200 (default — 3200 μ s)
18	Beginning of analog output range	0...16383 (default — 0)
19	End of analog output range	0...16383 (default — 16383)
20	Time lock of result	0...255 Specifies the time interval in increments of 5 ms.
21	Zero point	0...16383 (default — 0)
22-38	Reserved	
39	Change the protocol (RS interface)	0 — ACUITY protocol; 1 — ASCII protocol; 1 — MODBUS RTU protocol.
40	Save/recover the settings	0x00AA — Save current parameters to FLASH-memory 0x0069 — Restore the default parameters
41	Latch a current result	0 — nothing will happen; 1 — a result will be latched.

ASCII format

Data exchange with the sensor in ASCII format is carried out via the RS232 or RS485 interfaces. The command always consists of the request code (see the

table below), followed by the symbols CR and LF. The description of commands and the structure of answers are given below.

Request code + <CR><LF>	Name	Description	Answer
PRT	Changing the data format	After entering a command and receiving an answer, the sensor will change the ASCII format to the ACUITY binary protocol.	"OK" line (OK<CR><LF>)
V	Device identification	Information about the device type, firmware version, serial number, base distance and measurement range.	- device type (603<LF>) - firmware version (40<LF>) - serial number (19999<LF>) - base distance (125<LF>) - measurement range (500<CR><LF>)

Request code + <CR><LF>	Name	X values	Answer (line + <CR><LF>)
Wx	Working with FLASH-memory	0 - save current parameters to FLASH-memory; 1 - recover default values of parameters in FLASH-memory	0 – "OK" line 1 – "OK" line
Rx	Request of a result	0 - in increments (0 .. 16384); 1 - in millimeters; 2 - in inches.	"1124.4200" line "0223.0870" line "0099.8204" line
Ox	Sensor ON	1 - laser is ON, measurements are taken (default state); 0 - laser is OFF, sensor in power save mode.	0 – "OK" line 1 – "OK" line
Ax	Analog output ON	1 - analog output is ON; 0 - analog output is OFF.	0 – "OK" line 1 – "OK" line
TMx	Control of averaging mode	0 - averaging over a number of results (default); 1 - time averaging (5 ms).	0 – "OK" line 1 – "OK" line
TLx	Control of logic output mode	0 - out of the range indication (default); 1 - mutual synchronization mode; 2 - hardware zero set mode; 3 - laser switch OFF/ON.	0 – "OK" line 1 – "OK" line 2 – "OK" line 3 – "OK" line

TAx	Control of analog output mode	0 - window mode (default); 1 - full range.	0 – “OK” line 1 – “OK” line
TSx	Control of sampling mode	0 - time sampling (default); 1 - trigger sampling.	0 – “OK” line 1 – “OK” line
Bxxx	Rate of data transfer (RS232 / RS485)	1...192 (default - 4) Specifies data transfer rate in increments of 2400 baud; e.g., 4 means the rate of 4*2400=9600 baud.	“OK” line
Gxxx	Number of averaged values	1...128 (default - 1)	“OK” line
Sxxxxx	Sampling period	1) 10...65535 (default - 5000) The time interval in increments of 1 μ s with which sensor automatically communicates the results on streaming request (priority of sampling = 0). 2) 1...65535 Divider ratio of trigger input (priority of sampling = 1).	“OK” line
Exxxx	Maximum integration time	2...3200 (default - 3200) The limiting time of integration by CMOS-array in increments of 1 μ s.	“OK” line
Dxxx	Time lock of result	0...255 Specifies the time interval in increments of 5 ms.	“OK” line
Zxxxxx	Zero point	0...16384 (default - 0) Specifies the beginning of absolute coordinate system. Z* - reset to 0.	“OK” line

Analog outputs

Changing of the signal at the analog output occurs synchronously with changing of the result transferred through the bit-serial interface.

Current output 4...20 mA

The connection scheme is shown in the figure. The value of load resistor should not be higher than 500 Ohm. To reduce noise, it is recommended to install RC filter before the measuring instrument. The filter capacitor value is indicated for

maximum sampling frequency of the sensor (9.4 kHz) and this value increases in proportion to the frequency reduction.

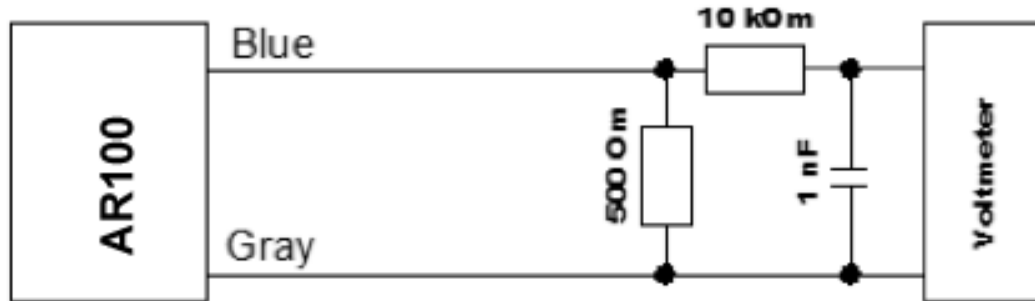

Voltage output 0...10 V

The connection scheme is shown in the figure. To reduce noise, it is recommended to install RC filter before the measuring instrument. The filter capacitor value is indicated for maximum sampling frequency of the sensor (9.4 kHz) and this value increases in proportion to the frequency reduction.

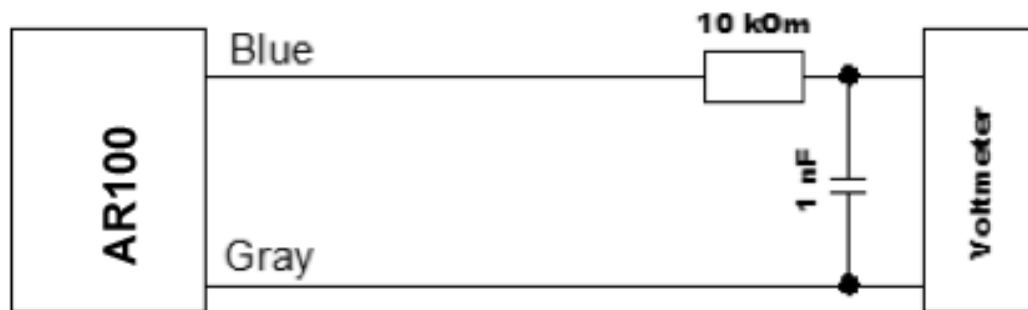

Configuration parameters

Range of the analog output

While working with the analog output, resolution can be increased by using the 'Window in the operating range' function which makes it possible to select a window of required size and position in the operating range of the sensor within which the whole range of analog output signal will be scaled.

Note. If the beginning of the range of the analog signal is set at a higher value than the end value of the range, this will change the direction of rise of the analog signal.

Analog output operation mode

When using the 'Window in the operating range' function, this mode defines the analog output operation mode.

Analog output can be:

- in the window mode or
- in the full mode.

"Window mode". The entire range of the analog output is scaled within the selected window. Outside the window, the analog output is "0".

"Full mode". The entire range of the analog output is scaled within the selected window (operating range). Outside the selected window, the whole range of the analog output is automatically scaled onto the whole operating range of the sensor (sensitivity range).

Factory parameters table

Parameter	Value
Range of the analog output	Measurement range of the sensor
Analog output operation mode	Window

Parameterization program

Function

The RF60X-SP-2.0 software is intended for:

- 1) Testing and demonstration of work of AR100 series sensors;
- 2) Setting of the sensor parameters;
- 3) Reception and gathering of the sensor data signals

Download link:

<https://www.acuitylaser.com>

Program setup

Run **RF60xsetup.exe** and follow the instructions of the installation wizard.

Obtaining connection to sensor (RS232/RS485)

Once the program is started, the main window appears:

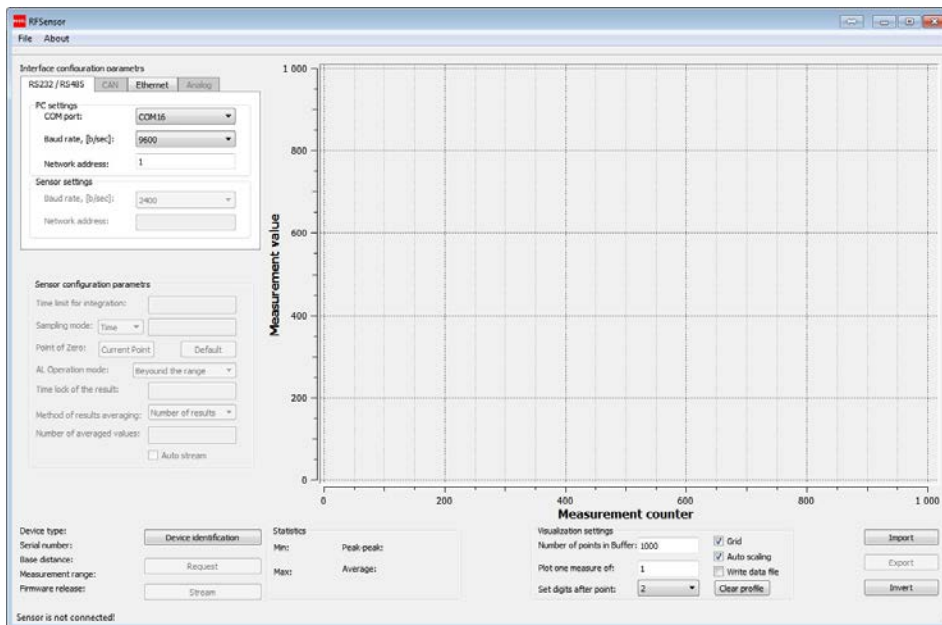

To obtain connection via RS232/RS485 interfaces, go to **RS232/RS485 PC settings** in the **Interface configuration parameters** panel:

- select the COM-port whereto the sensor is connected (logical port if the sensor is connected via USB-adapter);
- select the transmission rate (**Baud rate**) at which the sensor works;
- select the sensor network address, if necessary;
- press the **Device identification** button.

If the selected parameters correspond to the parameters of the sensor interface, the program will identify the sensor, read and display its configuration parameters:

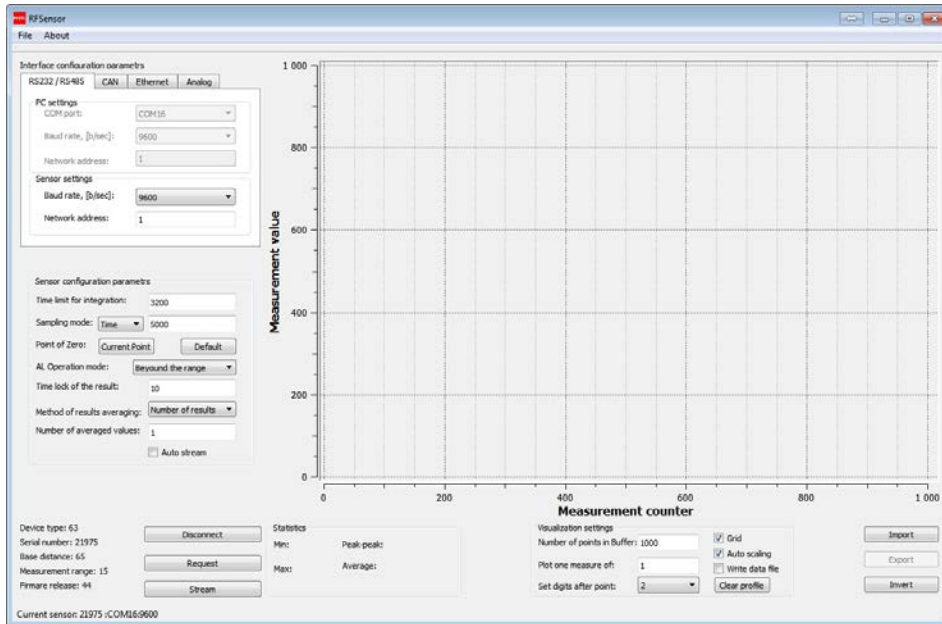

If connection is not established, a prompt window will appear asking to make the automatic search for the sensor:

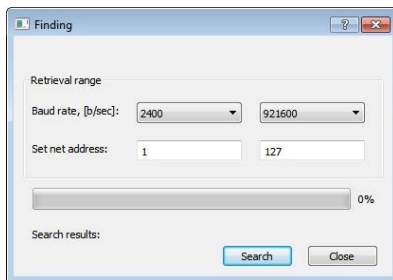

- set the range of transmission rate search in the **Baud rate** line;
- set the range of network address search in the **Net address** line;
- press the **Search** button.

The program will perform the automatic search for the sensor by searching over possible rates, network addresses and COM-ports of PC.

Checking of the sensor operability

Once the sensor is successfully identified, check its operability as follows:

- place an object inside the sensor working range;
- by pressing the **Request** button, obtain the result of one measurement on the (**Current result**) indicator. The 06h request type is realized
- pressing the **Stream** button will switch the sensor to the data stream transmission mode. The 07h request type is realized
- by moving the object, observe changes in the readings;
- the status line in the lower part of the window will show the current data transmission and refreshing rates.

To stop the data transmission, press the **Stop stream** button.

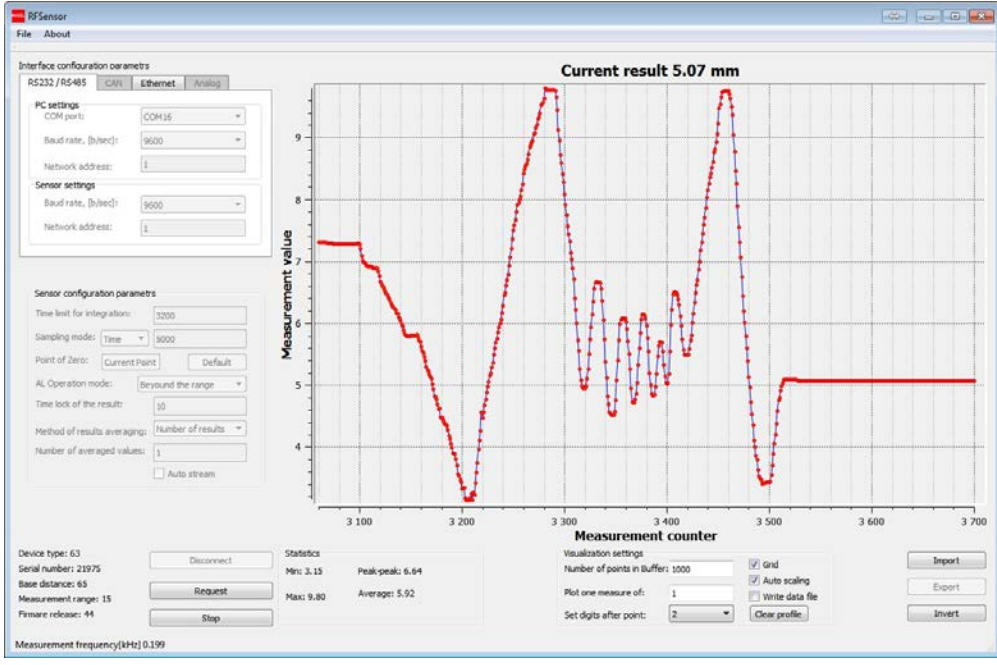

Connection via the ASCII interface

Select **File > Run the ASCII format:**

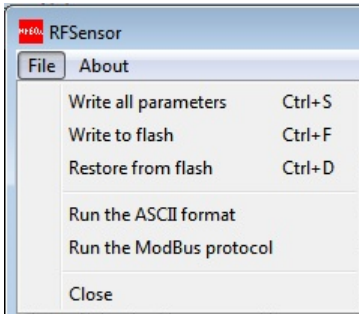

Use the emerged window to send commands:

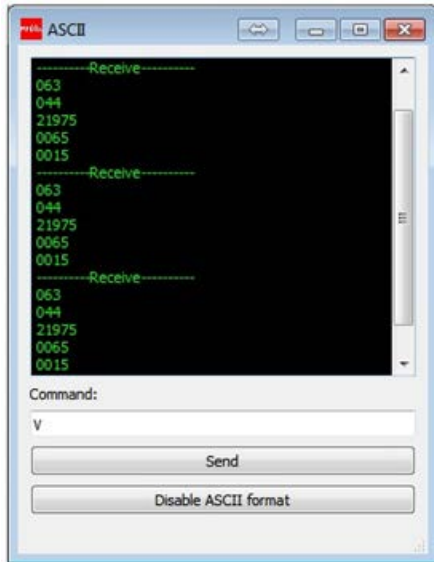

After closing the window, the sensor continues to work in the ASCII data format. To switch to the binary data format, click the **Disable ASCII format** button:

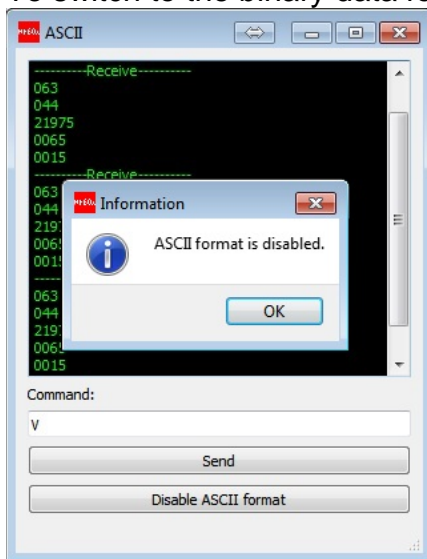

Connection via the Modbus RTU protocol

Select **File > Run Modbus protocol**.

To read the **Holding Registers**, select the corresponding option from the drop-down list in the lower left part of the window. Write the address of the initial register (**Address**) and their number (**Count**), then click **Send**.

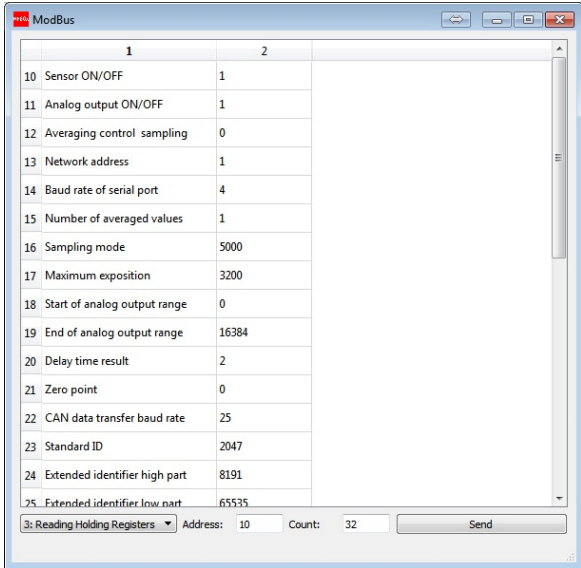

To read the **Reading Registers**, select the corresponding option:

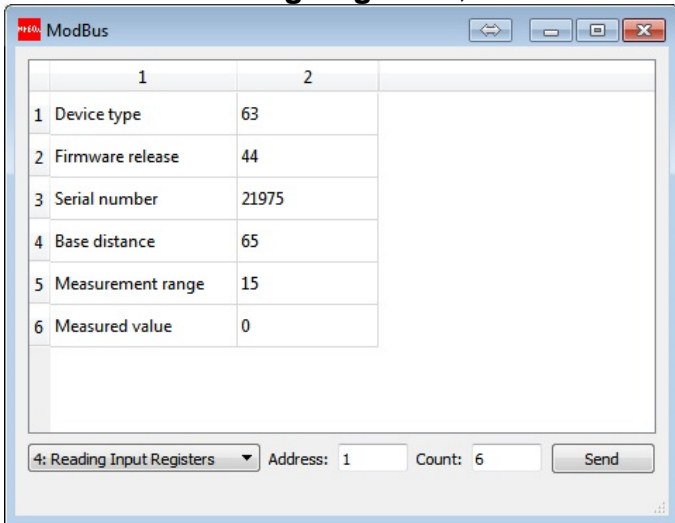

To write to the register, select **Write Single Register**, specify the address and required value, then click **Send**.

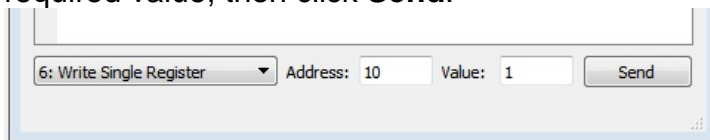

To change the protocol, write the required value to register 39 (0 - ACUITY protocol, 1 - ASCII format, 2 - MODBUS protocol).

Display, gathering and scanning of data

Measurement result is displayed in digital form and in the form of oscillogram and is stored in the PC memory.

- The number of points displayed along the X coordinate can be set in the **Number of points in buffer** window.
- Scaling method along the Y coordinate can be set by the **Auto scaling** function.
- Turn-on/turn-off of the scaling grid is affected by using the **Grid** function.
- The number of displayed digits after decimal point can be set in the **Set digits after point** window.
- To save received data to a file, select (tick) **Write data file**.

Note: the number of points displayed on the graph depends on PC speed and becomes smaller in proportion to the data transmission rate. After the stream is stopped by using the **Stop Stream** button, the graph will display all data received.

- To work with the image, press the right mouse key on the graph to call the corresponding menu:

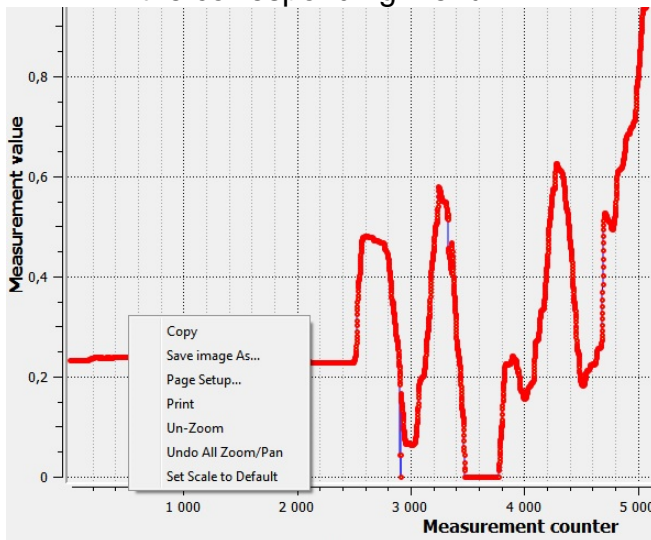

- To move the image, just press the mouse wheel.
- To zoom, rotate the mouse wheel.
- To save data to a file, press the **Export** button. The program will offer saving of data in two possible formats: internal and Excel.
- To scan or look at previously saved data, press the **Import** button and select the required file.

Setting and saving parameters of the sensor

Setting parameters

Setting of parameters for all interfaces can be done using the respective tabs on the **Interfaces configuration parameters** panel:

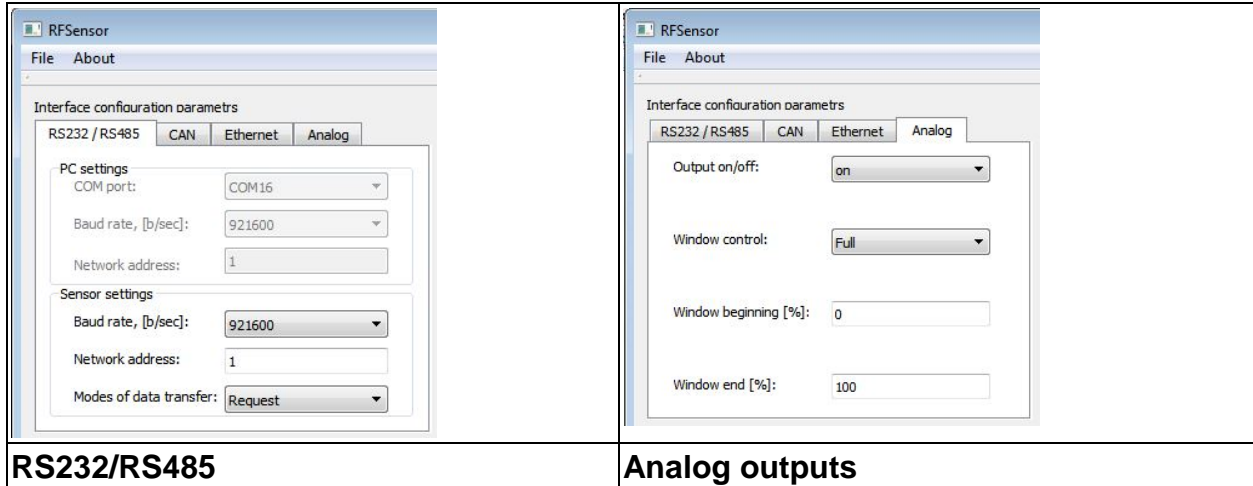
**RS232/RS485****Analog outputs**

Setting of all configuration parameters of the sensor is possible with the help of the respective panel (**Sensor configuration parameters**):

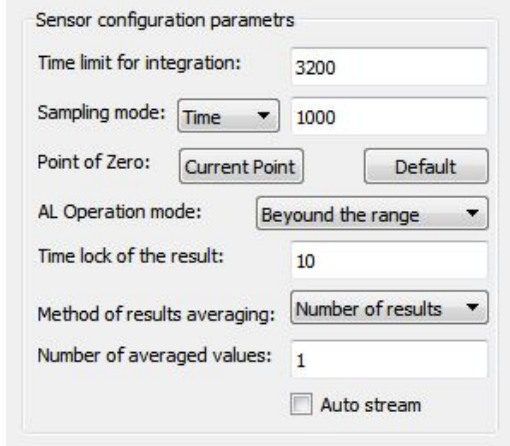

Automatic data stream mode after power switch on

By default, after the power supply is switched on, the sensor is waiting for the request result command. To get a continuous data stream after switching on the power supply, tick the **Auto stream** box. Save parameters (see below). Now with any subsequent activation of the sensor it will work in the data stream mode.

Saving parameters

- All parameters are applied immediately after setting.
- Perform testing of the sensor operation with new parameters.
- To store new parameters in nonvolatile memory, execute **File > Write to flash**. Now, with any subsequent activation of the sensor it will work in the configuration you have selected.

Saving and writing a set of parameters

Parameters of the sensor can be saved to a file. Select **File > Write parameters set** and save the file in the window offered.

To call a group of parameters from a file, select **File > Sensor parameters sets...** and select the file required. **Note:** these functions are convenient to use if it is necessary to write identical parameters to several sensors.

Recovery of default parameters

To restore the sensor parameters set by default, use File > Restore from flash.