

AccuRange™ Line scanner for Acuity® laser rangefinders



The **AccuRange laser line scanner** is precise spinning mirror assembly that when coupled with Acuity's laser rangefinder, creates a laser scanner. The laser scanner sweeps a laser spot through a 360° rotation for the accurate measuring of profiles and scenes. The AccuRange line scanner is often further integrated to create a 3D laser scanner.

To implement Acuity's 2D laser line scanner, it is necessary to use the AR4000 laser rangefinder, the AccuRange line scanner and a high speed interface card. The HSIF card increases the sampling rate and reads the encoder on back of the spinning mirror. The result is an accurate collection of point cloud data in polar coordinate form.

Technical Specifications

Weights

Full assembly with rangefinder	3.5 lb. (1.6 Kg)
Rotating mirror only	6.5 oz. (0.2 kg)

Mirror

Dimensions	ellipse 2.5 X 3.5 in. (63.5 X 88.9 mm)
Orientation	45° from axis of rotation
Reflectance	first-surface, 96% reflectance

Motor

Speed	Maximum of 2600 RPM at 12 VDC
-------	-------------------------------

Encoder

Resolution	Agilent® 6540, 4096 counts per revolution
Output	two-channel quadrature plus index pulse

Environmental

spinning mirror is exposed, use up to 50°C



Line Scanner components

To implement Acuity's 2D laser line scanner, it is necessary to use the AR4000 laser rangefinder, the AccuRange line scanner and a high speed interface (HSIF) card. The HSIF card increases the sampling rate of the rangefinder up to 200 KHz and reads the encoder on back of the spinning mirror. The result is an accurate collection of point cloud data in polar coordinate form.

Motor Control

The HSIF card comes with two variable voltage motor control outputs which allow the user to vary the motor speed on the line scanner. A separate power supply is required to drive the motors.

Maximum drive power	0.5A at 15V
Power control resolution	1 part in 256

Encoder Reading

The HSIF is equipped with two 32-bit motor encoder readers. The board can be designated with either single-ended or differential receivers. In both cases, the input stream is a 2-channel quadrature plus an index pulse. The output is 8-bit motor positions inserted in the sensor data stream.

Environmental Considerations

The AccuRange line scanner is a precise measuring device. The spinning mirror is balanced up to 2600 rpm by a weighted balance collar. The line scanner uses an exposed, spinning mirror to both project a laser and collect distance data via the reflected beam.

Mechanical (dimensions in inches)

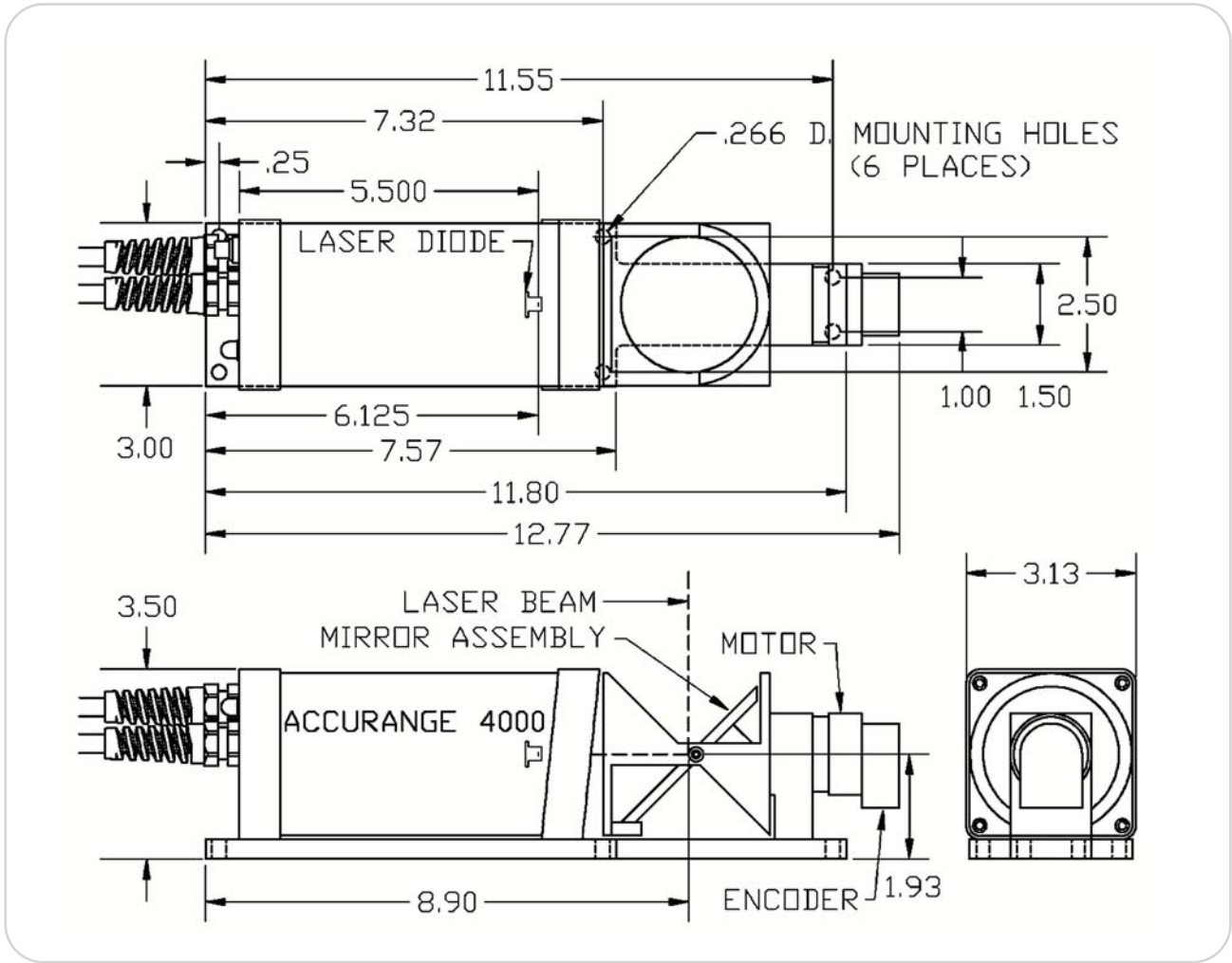

Accessories

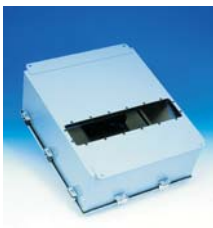

The AccuRange™ Line Scanner Environmental Enclosure houses the scanner and protects it in industrial areas.



AccuRange™ High Speed Interface for rapid sampling with AR4000 and mirror position encoding for the Line Scanner.

Acuity Laser Measurement product of



Schmitt Measurement Systems, Inc.
 2765 NW Nicolai St.
 Portland, OR 97210
 Tel: 503-227-5178 Fax: 503-227-5040
www.acuityresearch.com